



Most Widely Accepted and Trusted

ICC-ES Evaluation Report

ESR-1687

ICC-ES | (800) 423-6587 | (562) 699-0543 | www.icc-es.org

Reissued 02/2019

This report is subject to renewal 02/2020.

DIVISION: 07 00 00—THERMAL AND MOISTURE PROTECTION
SECTION: 07 42 43—COMPOSITE WALL PANELS

REPORT HOLDER:

TRESPA NORTH AMERICA, LTD.

EVALUATION SUBJECT:

TRESPA METEON FR WALL PANEL CLADDING SYSTEM



“2014 Recipient of Prestigious Western States Seismic Policy Council (WSSPC) Award in Excellence”



ICC-ES Evaluation Reports are not to be construed as representing aesthetics or any other attributes not specifically addressed, nor are they to be construed as an endorsement of the subject of the report or a recommendation for its use. There is no warranty by ICC Evaluation Service, LLC, express or implied, as to any finding or other matter in this report, or as to any product covered by the report.



ICC-ES Evaluation Report

ESR-1687

Reissued February 2019

This report is subject to renewal February 2020.

www.icc-es.org | (800) 423-6587 | (562) 699-0543

A Subsidiary of the International Code Council®

DIVISION: 07 00 00—THERMAL AND MOISTURE PROTECTION

Section: 07 42 43—Composite Wall Panels

REPORT HOLDER:

TRESPA NORTH AMERICA, LTD.

EVALUATION SUBJECT:

TRESPA METEON FR WALL PANEL CLADDING SYSTEM

1.0 EVALUATION SCOPE

1.1 Compliance with the following codes:

- 2015, 2012, 2009 and 2006 *International Building Code*® (IBC)
- 2015, 2012, 2009 and 2006 *International Residential Code*® (IRC)
- 2013 *Abu Dhabi International Building Code* (ADIBC)[†]

[†]The ADIBC is based on the 2009 IBC. 2009 IBC code sections referenced in this report are the same sections in the ADIBC.

For evaluation for compliance with codes adopted by the Los Angeles Department of Building and Safety (LADBS), see [ESR-1687 LABC and LARC Supplement](#).

Properties evaluated:

- Weather resistance
- Wind load resistance
- Interior finish
- Types I, II, III or IV construction

1.2 Evaluation to the following green code:

- 2016 California Green Building Standards Code (CALGreen), Title 24, Part 11
- 2015, 2012 and 2008 ICC 700 *National Green Building Standard*™ (ICC 700-2015, ICC 700-2012 and ICC 700-2008)

Attributes verified:

See Section 2.0.

2.0 USES

The Trespa Meteon FR Wall Panel Cladding System is used as a nonload-bearing exterior wall covering in accordance with Chapter 14 of the IBC. The system may also be used for interior applications as part of a Class A

interior wall finish. The Trespa Meteon FR Wall Panel Cladding System may be installed on buildings of all construction types under the IBC and buildings constructed in accordance with the IRC. Use on buildings of Types I, II, III or IV construction must be in accordance with Section 4.4 of this report.

The attributes of the Trespa Meteon FR Wall Panel Cladding System have been verified as conforming to the provisions of (i) CALGreen Sections A4.405.1.3 (prefinished materials) and A5.406.1.2 (reduced maintenance); (ii) ICC 700-2015 and ICC 700-2012 Sections 601.7, 11.601.7, and 12.1(A).601.7 (site-applied finishing materials); and (iii) ICC 700-2008 Section 601.7 (site-applied finishing materials). Note that decisions on compliance for those areas rest with the user of this report. The user is advised of the project-specific provisions that may be contingent upon meeting specific conditions, and the verification of those conditions is outside the scope of this report. The code may provide supplemental information as guidance.

3.0 DESCRIPTION

3.1 General:

The Trespa Meteon FR Wall Panel Cladding System is an open-jointed wall covering system that allows air to circulate between the panels and the exterior face of the installed water-resistive barrier or mineral wool insulation. The panels are mounted with visible or concealed fasteners, on extruded aluminum substructure systems composed of tracks and mounting brackets. When used as an exterior wall covering, the system must be installed over a water-resistive barrier. See Figures 1–4 for system details.

3.2 Components:

3.2.1 Panels: Trespa Meteon FR wall panels are panels composed of thermosetting resins homogeneously reinforced with cellulose fibers, and are manufactured using high pressure and temperature. The panels have an integrated decorative surface created using Electron Beam curing (EBC) technology. Trespa Meteon FR wall panels are available in nominal sheet thicknesses of ⁵/₁₆ inch, ³/₈ inch and ¹/₂ inch (8 mm, 10 mm and 13 mm) in a variety of sheet sizes, colors, finishes and textures. The ⁵/₁₆-inch, ³/₈-inch and ¹/₂-inch panels weigh 2.4 psf, 3.0 psf, and 3.8 psf (11.7, 14.7, and 18.6 kg/m²), respectively.

The Trespa Meteon FR wall panels meet the requirements of IBC Section 803.1.1 to be considered a Class A interior finish when tested in accordance with ASTM E84.

3.2.2 Substructure System: The substructure is a system of rail extrusions made of ASTM B317, 6063-T5 or -T6 alloy aluminum, which are fastened to the existing building and to each other to provide support for the panels. The panels are connected to the substructure with exposed fasteners (TS110 system) or concealed brackets and fasteners (TS210 system). The TS210 system bracket must be manufactured from 6063 T5 aluminum. See Figure 1 for bracket and rail profiles. The exposed fastening system is for use with all three panel thicknesses; the concealed fastening system is for use with the $\frac{3}{8}$ -inch-thick and $\frac{1}{2}$ -inch-thick panels only. The hat channel weighs 1.1 lbs/ft (1.6 kg/m) and the J-channel and rail extrusions each weigh 1.0 lb/ft (1.5 kg/m).

Connection of the substructure to the underlying wall assembly must be designed in accordance with Section 4.2.

4.0 DESIGN AND INSTALLATION

4.1 General:

The Trespa Meteor FR Wall Panel Cladding Systems (panels and substructure) must be installed over existing wall assemblies capable of supporting the imposed loads including, but not limited to, transverse wind loads. The Trespa Meteor FR Wall Panel Cladding Systems must be securely connected to the supporting wall with fasteners that are compatible with the wall assembly substrate.

4.2 Design:

The allowable loads for the Trespa Meteor FR Wall Panel Cladding System, given in Table 1, and the wind-load capacity of the underlying wall and substrate must equal or exceed the design uniform transverse wind loads determined in accordance with Chapter 16 of the IBC or Section R301.2.1 of the IRC, as applicable. The substructure system connections used to connect the Trespa Meteor FR Wall Panel Cladding System to the underlying wall or substrate must be designed by a design professional and the details must be submitted to the code official for approval. The allowable loads must be reduced to the capacity of the attachment system connections if these are less than the values in Table 1. All fasteners used to connect the substructure system to exterior walls must be corrosion-resistant.

The cladding system must be designed to conform to an $L/175$ panel deflection criteria. The maximum panel fastener spacing to achieve this deflection criteria at a transverse wind load of 23 psf (1.05 kN/m²) is given in Table 1. Table 1 also shows the maximum allowable positive and negative transverse wind loads for the Trespa Meteor FR wall panels installed in accordance with this report.

4.3 Installation:

4.3.1 General: The Trespa Meteor FR Wall Panel Cladding System must be installed in accordance with the manufacturer's published installation instructions, the project-specific structural calculations, and this report by installers trained by Trespa. A copy of the manufacturer's published installation instructions must be available on the jobsite at all times during construction.

The system must be installed over wall assemblies complying with IBC Section 1403.3, using the substructure systems described in Section 3.2.2. The aluminum substructure, brackets, and fasteners must be provided with the panels. The panels may be cut to accommodate various architectural designs and must be fastened as determined by the structural calculations.

Exterior wall assemblies, on which the system is to be

installed, must include flashing, a water-resistive barrier, a means of draining water, and protection against condensation in accordance with IBC Section 1403.2. A ventilation path must be maintained to allow air to flow into, out of, and within the cavity between the water-resistive barrier and the panels. Panel-to-panel joints and panel-to-penetration joints (such as at windows, doors, and air conditioning outlets) require a minimum gap of $\frac{3}{8}$ inch (10 mm). To restrict pest and vermin access to the ventilation cavity, a vent screen may be installed at the base of the system and at window and door heads. The vent screen is composed of a perforated aluminum angle to cover the opening. Ventilation perforations must allow for a minimum opening of 2.36 square inches per linear foot (464 mm²/m).

Joint closures may be installed at horizontal joints and/or corner closures may be installed at vertical corner joints as decorative elements when specified by the building designer.

4.3.2 TS110 Exposed Fastener System: Trespa's TS110 exposed fastener system (see Figure 2) for use with $\frac{5}{16}$ -inch, $\frac{3}{8}$ -inch and $\frac{1}{2}$ -inch (8 mm, 10 mm and 13 mm) panels utilizes two aluminum substructure components: a J-channel and a hat channel (see Figure 1). The J-channel has an overall width of 3 inches (76 mm) and a total depth of 1 inch (25 mm). The hat channel has an overall width of $5\frac{3}{4}$ inches (146 mm) and a total depth of 1 inch (25 mm). The J-channels and hat channels are installed vertically and connected to the underlying structure of the building. The spacing of the channels and their attachment to the substrate must be in accordance with the project-specific structural calculations provided by the building designer. The substructure channel anchorage to attach the channels to the building must be of stainless steel.

Trespa Meteor FR wall panels must be secured to the TS110 substructure system using 1-inch-long (25 mm), Torx head, No. 12-11, stainless steel screws. Each wall panel, at the panel attachment point, must be predrilled maintaining a minimum fastener edge distance of 2 inches (50 mm).

4.3.3 TS210 Concealed Fastener System: Trespa's TS210 concealed fastener system (see Figure 3), for use with $\frac{3}{8}$ -inch and $\frac{1}{2}$ -inch (10 mm and 13 mm) panels, utilizes three extruded aluminum substructure components: a J-channel, a rail extrusion and a panel bracket (see Figure 1). The rail extrusion has an overall depth of $1\frac{1}{4}$ inches (32 mm) and a total width of $2\frac{3}{8}$ inches (60 mm). The panel bracket has an overall width of $1\frac{3}{16}$ inches (30 mm) and total height of $2\frac{7}{16}$ inches (62 mm). The J-channels are installed vertically and connected to the underlying structure of the building. The substructure channel anchorage to attach the channels to the building must be of stainless steel; the spacing must be in accordance with the project-specific structural calculations provided by the building designer.

The rail extrusion is oriented horizontally and is fastened to the vertical J-channels using a $\frac{1}{4}$ -14 by 1-inch-long (25 mm) stainless steel rail anchor fastener. Rail extrusions are installed continuously across the entire building elevation and must not cantilever more than 6 inches (152 mm) beyond an attachment point. Panel brackets are attached to the Trespa Meteor FR wall panels at predetermined locations using SFS TU-S-6 stainless steel blind rivets. The expansion anchor is inserted through the panel bracket into the predrilled hole in the panel and is expanded into the panel. The length of the rivet is matched to the thickness of the panel in accordance with the Trespa published installation

instructions. A minimum fastener edge distance of $3\frac{1}{4}$ inches (83 mm) must be maintained. The panels, with the bracket attached, are then installed onto the horizontal rail extrusion. To prevent lateral movement, each panel is secured in place by installing a screw through the centermost top bracket into the rail extrusion.

4.4 Types I, II, III or IV Construction:

When installed as described in this section, the Trespa Meteor FR wall panels may be used on the exterior face of exterior walls of buildings required to be of Type I, II, III or IV construction.

Note: Five-sixteenths-inch-thick (8 mm) Trespa Meteor FR wood decor (NW) and natural (NA) prints are excluded from use where Types I, II, III or IV construction is required.

4.4.1 TS110-285 Exposed Fastener System: The supporting wall must consist of minimum 6-inch-by- $1\frac{5}{8}$ -inch (152 mm by 41.3 mm), 20 gage steel studs spaced 16 inches (406 mm) on center. Lengths of 8-inch-wide (203 mm), 14 gage, steel backing strips must be installed horizontally across the exterior side of the studs to act as fastening strips, spaced 24 inches (610 mm) on center. The stud cavities must be filled with R-19 unfaced thermal insulation batts. Each face of the studs must be covered with $\frac{5}{8}$ -inch (15.9 mm), Type X gypsum board, wallboard on the interior side and sheathing on the exterior side, installed with the long dimension perpendicular to the studs. The gypsum board must be fastened to the steel framing with No. 6 by $1\frac{1}{4}$ -inch-long (31.8 mm), Type S, bugle head screws at 8 inches (203 mm) on center around the perimeter and 12 inches (305 mm) on center in the field. The exterior side of the sheathing must be covered with a water-resistive barrier recognized in a current ICC-ES evaluation report, that has a flame-spread rating of 25 or less and a smoke developed rating of 450 or less in accordance with ASTM E84 and is installed per manufacturer's guidelines. Under the 2015 and 2012 IBC, the water-resistive barrier installed over the exterior sheathing in building heights greater than 40 feet (12.2 m) must be either of the water-resistive barriers listed in Table 2 of this report. The Trespa Meteor FR Wall Panel Cladding System must be installed as described in Section 4.3.2, with a maximum free air cavity depth of 1 inch (25 mm).

4.4.2 TS210-285 Concealed Fastener System: The supporting wall must consist of minimum 6-inch-by- $1\frac{5}{8}$ -inch (152 by 41.3 mm), 20 gage steel studs spaced 16 (406 mm) inches on center. Lengths of 8-inch-wide (203 mm), 14 gage, steel backing strips must be installed horizontally across the exterior side of the studs to act as fastening strips, spaced 24 inches (610 mm) on center. The stud cavities must be filled with R-19 unfaced thermal insulation batts. Each face of the studs must be covered with $\frac{5}{8}$ -inch (15.9 mm), Type X gypsum board, wallboard on the interior and sheathing on the exterior, installed with the long dimension perpendicular to the studs. The gypsum board must be fastened to the steel framing with No. 6 by $1\frac{1}{4}$ -inch-long (31.8 mm), Type S, bugle head screws at 8 inches (203 mm) on center around the perimeter and 12 inches (305 mm) on center in the field. The exterior side of the sheathing must be covered with a water-resistive barrier recognized in a current ICC-ES evaluation report, that has a flame-spread rating of 25 or less and a smoke developed rating of 450 or less in accordance with ASTM E84 and is installed per manufacturer's guidelines. Under the 2015 and 2012 IBC, the water-resistive barrier installed over the exterior sheathing in building heights greater than 40 feet (12.2 m) must be either of the water-resistive barriers listed in Table

2 of this report. The Trespa Meteor FR Wall Panel Cladding System must be installed as described in Section 4.3.3. A layer of minimum 1-inch-thick (25 mm) mineral wool unfaced thermal insulation must be installed over the water-resistive barrier and between the vertical J-channels. The insulation must be classified as noncombustible in accordance with ASTM E136 and have a density between 3 and 9 pcf (48 and 144 kg/m³). A $\frac{1}{2}$ -inch-thick (12.7 mm) aluminum spacer block must be installed behind the horizontal rail such that a $\frac{1}{2}$ -inch (12.7 mm) air space is created between the horizontal rail and the mineral wool insulation. The maximum free air cavity depth is $\frac{1}{2}$ inch (12.7 mm). See Figure 4 for details.

5.0 CONDITIONS OF USE

The Trespa Meteor FR Wall Panel Cladding System described in this report complies with, or is a suitable alternative to what is specified in, those codes listed in Section 1.0 of this report, subject to the following conditions:

- 5.1 Installation must comply with this report, the manufacturer's published installation instructions and the applicable code. If there is a conflict between the installation instructions and this report, this report governs.
- 5.2 The underlying support structure and substrate must be adequate to resist the positive and negative transverse wind loads shown in Table 1.
- 5.3 Drawings, design details and calculations verifying compliance with this report and adequacy of the connections and supporting framing, must be submitted to the code official for approval. The drawings and calculations must be prepared by a registered design professional when required by the statutes of the jurisdiction in which the project is to be constructed.
- 5.4 The Trespa Meteor FR Wall Panel Cladding System must be installed by installers trained by Trespa North America, Ltd..
- 5.5 The maximum allowable wind pressures for the Trespa Meteor FR Wall Panel Cladding System are shown in Table 1. The capacity of the supporting wall or substrate, and the capacity of the connections used to attach the system to the wall, must be equal to or exceed the design wind pressure. The maximum panel fastener/support spacing to maintain a deflection of $L/175$ is noted in Table 1.
- 5.6 A water-resistive barrier complying with IBC Section 1403.2 must be installed behind the wall panel system and over the wall sheathing.
- 5.7 When installed with spaces between adjacent panels on interior walls, the Trespa Meteor FR Wall Panel Cladding System must be installed over a substrate having a Class A finish.
- 5.8 Trespa Meteor FR wood decor (NW) and natural (NA) print wall panels, $\frac{5}{16}$ inch thick (8 mm), are excluded from use where Types I, II, III or IV construction is required.
- 5.9 The panels are manufactured in Weert, the Netherlands, under a quality control program with inspections by ICC-ES.

6.0 EVIDENCE SUBMITTED

Data in accordance with the ICC-ES Acceptance Criteria for Polymer-based and Polymer-modified Exterior and Interior Wall Cladding (AC92), dated December 2013

7.0 IDENTIFICATION

7.1 The Trespa Meteon FR wall panels are labeled with the manufacturer’s name (Trespa International BV) and address, the product name, thickness, color, finish, batch number, the evaluation report number (ESR-1687).

7.2 The report holder’s contact information is the following:

TRESPA NORTH AMERICA, LTD.
350 FIFTH AVENUE, SUITE 4610
NEW YORK, NEW YORK 10118
(800) 487-3772
www.trespa.com

TABLE 1—MAXIMUM FASTENER SPACING AND ALLOWABLE TRANSVERSE LOADS

SYSTEM TYPE	PANEL THICKNESS	MAXIMUM FASTENER/SUPPORT SPACING ²	ALLOWABLE TRANSVERSE LOAD ¹ (psf)	
			Positive	Negative
Exposed fastener system	⁵ / ₁₆ inch (8 mm)	23 inches (584 mm)	38	32
	³ / ₈ inch (10 mm)	30 ⁵ / ₈ inches (778 mm)	38	32
	¹ / ₂ inch (13 mm)	46 inches (1168 mm)	38	26
Concealed fastener system	³ / ₈ inch (10 mm)	29 ⁷ / ₈ inches (759 mm)	50	23
	¹ / ₂ inch (13 mm)	44 ³ / ₄ inches (1137 mm)	50	38

For **SI**: 1 inch = 25.4 mm; 1 psf = 47.9 N/m².

¹Maximum transverse wind load capacity determined from ASTM E330 testing.

²Testing was carried out in a multispan support configuration.

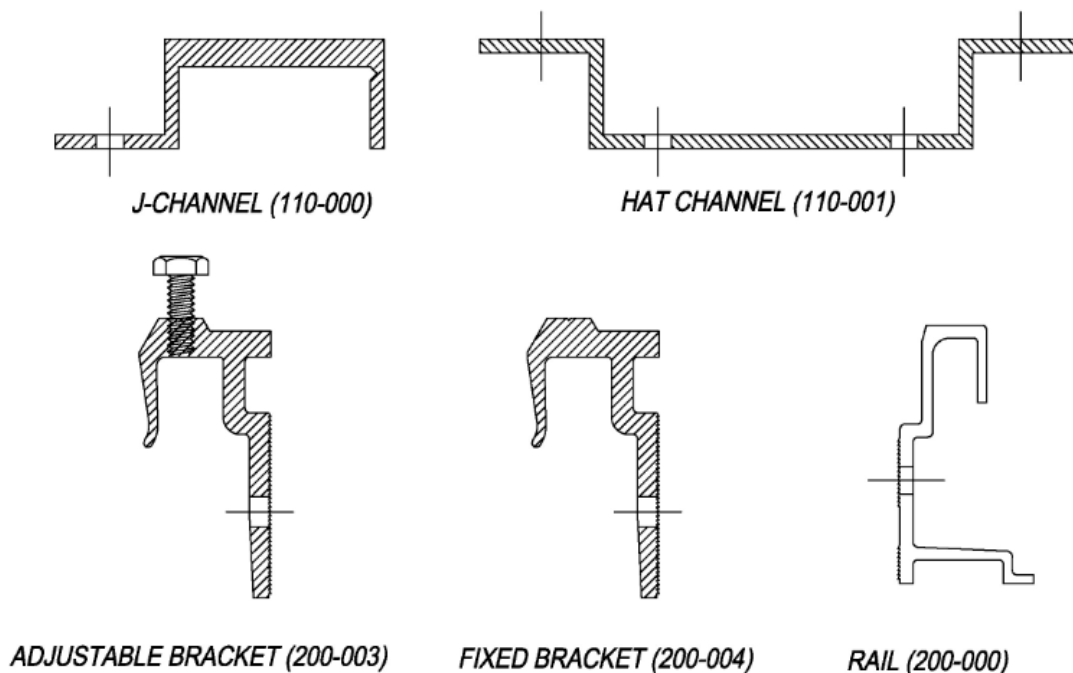

FIGURE1 - STANDARD SYSTEMS COMPONENTS

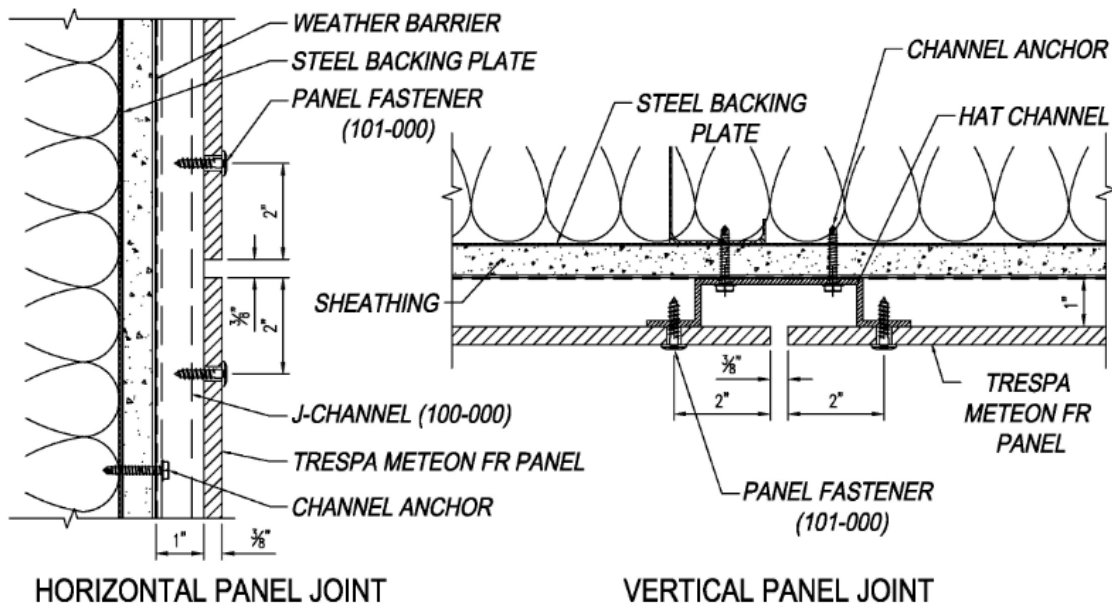

FIGURE 2 - TS110 EXPOSED FASTENER SYSTEM

TABLE 2—WATER-RESISTIVE BARRIERS RECOGNIZED FOR EXTERIOR WALL ASSEMBLIES IN TYPES I, II, III OR IV CONSTRUCTION

Manufacturer	Water-resistive Barrier
VaproShield LLC	WrapShield® ¹
	WallShield® ¹
	WrapShield® SA Self-Adhered ^{1,2}
	RevealShield™ ¹
	RevealShield SA™ ¹
Cosella-Dorken Products, Inc.	Delta®-Foxx (ESR-2932)
	Delta®-Fassade S (ESR-2932)
DuPONT™	Tyvek® Commercial Wrap® (ESR-2375)
	Tyvek® Commercial Wrap® D (ESR-2375)
	Tyvek® ThermaWrap™ (ESR-1993)
Momentive Performance Materials	GE Elemax 2600 (ESR-3983)
Kingspan Insulation, LLC	GreenGuard® C2000 ¹
	GreenGuard® Max™ ¹
	GreenGuard® RainDrop® ¹
W.R. Meadows	Airshield™ LMP
	Airshield™ TMP

¹ Recognition of listed water-resistive barriers as complying with IBC Section 1404.2 is outside scope of this report.

² The WrapShield SA water-resistive barrier must be covered by a minimum of 1-inch thick mineral wool insulation complying with the following requirements:

- Complies with ASTM C612
- Must not have a facer (foil, etc.) on either side
- Must be noncombustible complying with ASTM E136
- Density must range from 3 to 9 pcf (48 to 144 kg/m³)
- Thermal resistance, R value/inch must range from 3.5 to 4.5
- Must be adequately attached

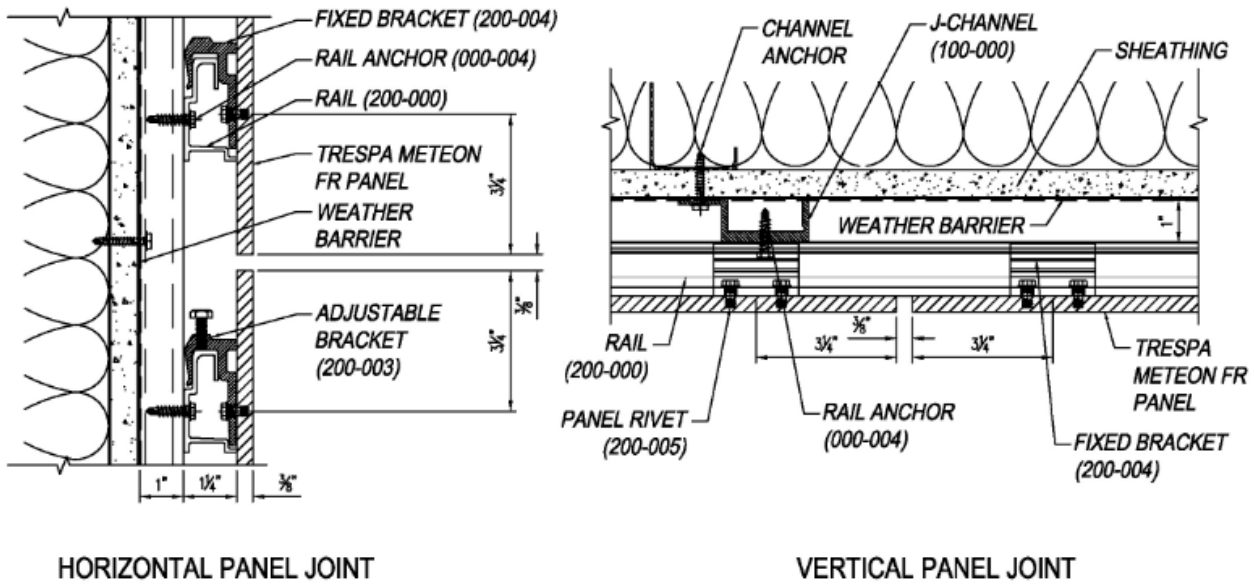

FIGURE 3 - TS210 CONCEALED FASTENER SYSTEM

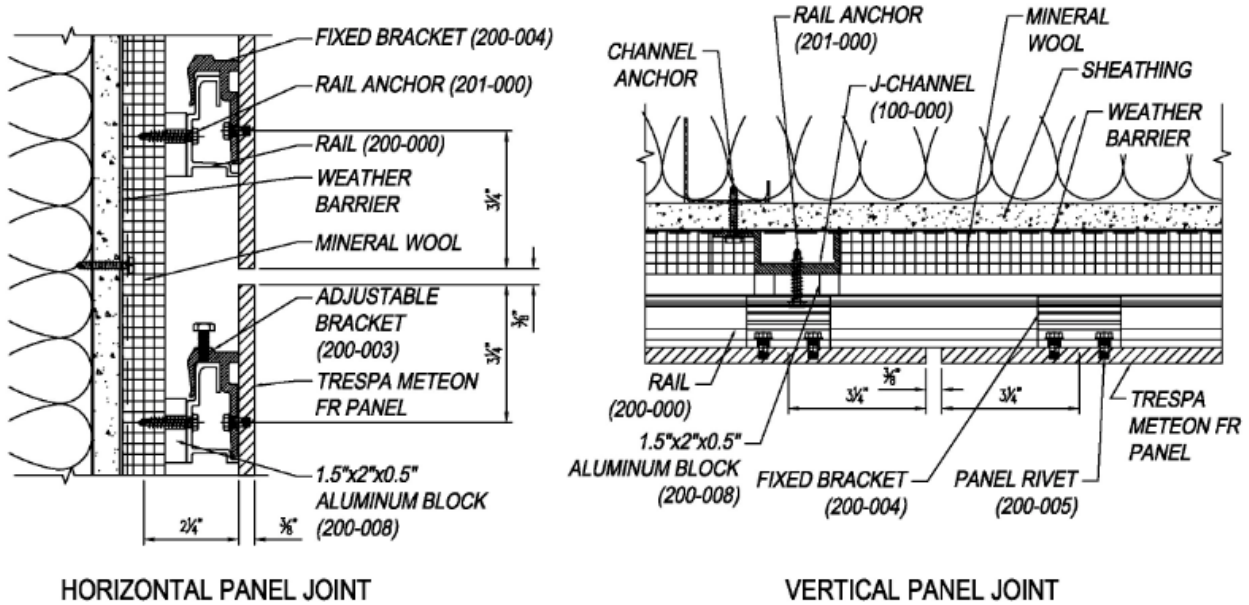

FIGURE 4 - TS210-285 CONCEALED FASTENER SYSTEM

ICC-ES Evaluation Report

ESR-1687 LABC and LARC Supplement

Reissued February 2019

This report is subject to renewal February 2020.

www.icc-es.org | (800) 423-6587 | (562) 699-0543 A Subsidiary of the International Code Council®

DIVISION: 07 00 00—THERMAL AND MOISTURE PROTECTION
Section: 07 42 43—Composite Wall Panels

REPORT HOLDER:

TRESPA NORTH AMERICA, LTD.

EVALUATION SUBJECT:

TRESPA METEON FR WALL PANEL CLADDING SYSTEM

1.0 REPORT PURPOSE AND SCOPE

Purpose:

The purpose of this evaluation report supplement is to indicate that the Trespa Meteon FR Wall Panel Cladding System, described in ICC-ES master evaluation report [ESR-1687](#), has also been evaluated for compliance with the codes noted below as adopted by the Los Angeles Department of Building and Safety (LADBS).

Applicable code editions:

- 2017 *City of Los Angeles Building Code* (LABC)
- 2017 *City of Los Angeles Residential Code* (LARC)

2.0 CONCLUSIONS

The Trespa Meteon FR Wall Panel Cladding System, described in Sections 2.0 through 7.0 of the master evaluation report [ESR-1687](#), complies with the LABC Chapters 8 and 14, and the LARC Chapter R7, and is subjected to the conditions of use described in this supplement.

3.0 CONDITIONS OF USE

The Trespa Meteon FR Wall Panel Cladding System described in this evaluation report must comply with all of the following conditions:

- All applicable sections in the master evaluation report [ESR-1687](#).
- The design, installation, conditions of use and identification of the Trespa Meteon FR Wall Panel Cladding System are in accordance with the 2015 *International Building Code*® (2015 IBC) provisions noted in the master evaluation report [ESR-1687](#).
- The design, installation and inspection are in accordance with additional requirements of the LABC Chapters 16 and 17, as applicable.
- The Trespa Meteon FR Wall Panel Cladding System, has not been evaluated under the LABC Chapter 7A or the LARC Section R337 for use in the exterior design and construction of new buildings located in any Fire Hazard Severity Zone within State Responsibility Areas or any Wildland—Urban Interface Area.

This supplement expires concurrently with the master report, reissued February 2019.

ICC-ES Evaluation Report

ESR-1687 CBC and CRC Supplement

Reissued February 2019

This report is subject to renewal February 2020.

www.icc-es.org | (800) 423-6587 | (562) 699-0543 A Subsidiary of the International Code Council®

DIVISION: 07 00 00—THERMAL AND MOISTURE PROTECTION
Section: 07 42 43—Composite Wall Panels

REPORT HOLDER:

TRESPA NORTH AMERICA, LTD.

EVALUATION SUBJECT:

TRESPA METEON FR WALL PANEL CLADDING SYSTEM

1.0 REPORT PURPOSE AND SCOPE

Purpose:

The purpose of this evaluation report supplement is to indicate that the Trespas Meteon FR Wall Panel Cladding System recognized in ICC-ES master evaluation report ESR-1687, has also been evaluated for compliance with the codes noted below.

Applicable code editions:

- 2016 *California Building Code*® (CBC)
- 2016 *California Residential Code*® (CRC)

2.0 CONCLUSIONS

2.1 CBC:

The Trespas Meteon FR Wall Panel Cladding System, described in Sections 2.0 through 7.0 of the master evaluation report ESR-1687, complies with CBC Chapters 8 and 14, provided the design and installation are in accordance with the 2015 *International Building Code*® (IBC) provisions noted in the master report and the additional requirements of the CBC Chapters 16 and 17.

The wall panel cladding system has not been evaluated under CBC Chapter 7A for use in the exterior design and construction of new buildings located in any Fire Hazard Severity Zone within State Responsibility Areas or any Wildland—Urban Interface Area.

2.2 CRC:

The Trespas Meteon FR Wall Panel Cladding System, described in Sections 2.0 through 7.0 of the master evaluation report ESR-1687, complies with CRC Chapter 7, provided the design and installation are in accordance with the 2015 *International Residential Code*® (IRC) provisions noted in the master report and the applicable provisions of the CRC.

The wall panel cladding system has not been evaluated under CRC Section R327 for use in the exterior design and construction of new buildings located in any Fire Hazard Severity Zone within State Responsibility Areas or any Wildland—Urban Interface Area.

The products recognized in this supplement have not been evaluated for compliance with the *International Wildland—Urban Interface Code*®.

This supplement expires concurrently with the master report, reissued February 2019.

ICC-ES Evaluation Report

ESR-1687 FBC Supplement

Reissued February 2019

This report is subject to renewal February 2020.

www.icc-es.org | (800) 423-6587 | (562) 699-0543

A Subsidiary of the International Code Council®

DIVISION: 07 00 00—THERMAL AND MOISTURE PROTECTION
Section: 07 42 43—Composite Wall Panels

REPORT HOLDER:

TRESPA NORTH AMERICA, LTD.

EVALUATION SUBJECT:

TRESPA METEON FR WALL PANEL CLADDING SYSTEM

1.0 REPORT PURPOSE AND SCOPE

Purpose:

The purpose of this evaluation report supplement is to indicate that Trespa Meteon FR Wall Panel Cladding System, recognized in ICC-ES master evaluation report ESR-1687, have also been evaluated for compliance with the codes noted below.

Applicable code editions:

- 2017 *Florida Building Code—Building*
- 2017 *Florida Building Code—Residential*

2.0 CONCLUSIONS

The Trespa Meteon FR Wall Panel Cladding System, described in Sections 2.0 through 7.0 of the master evaluation report ESR-1687, comply with the *Florida Building Code—Building* and *Florida Building Code—Residential*, provided the design and installation are in accordance with the *International Building Code*® (IBC) provisions noted in the master report under the following condition:

Installation must meet the requirements of Section 1403.8 of the *Florida Building Code—Building* and Section R318.7 of the *Florida Building Code—Residential*, as applicable.

Use of the Trespa Meteon FR Wall Panel Cladding System for compliance with the High-Velocity Hurricane Zone provisions of the *Florida Building Code—Building* and the *Florida Building Code—Residential* has not been evaluated and is outside the scope of this evaluation report.

For products falling under Florida Rule 9N-3, verification that the report holder's quality assurance program is audited by a quality assurance entity approved by the Florida Building Commission for the type of inspections being conducted is the responsibility of an approved validation entity (or the code official, when the report holder does not possess an approval by the Commission).

This supplement expires concurrently with the master report, reissued February 2019.